

Roof Curbs

SUBMITTAL

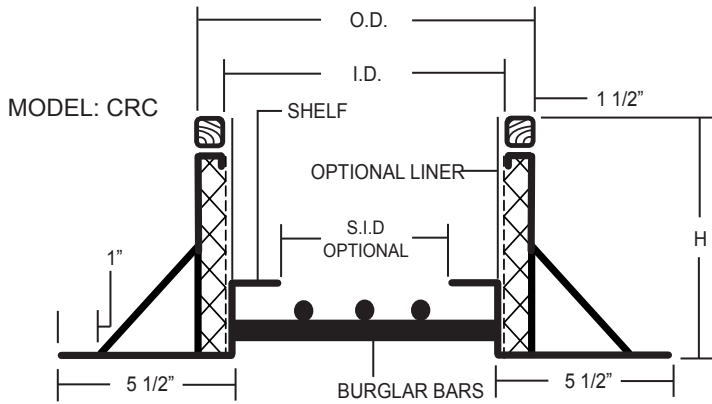

PROJECT
LOCATION
ARCHITECT
ENGINEER
CONTRACTOR

STANDARD FEATURES

- 18 GA. Welded Galvanized Steel Construction
- 8" & 12" Standard Height (H)
- 2" X 2" Wood Nailer
- Welded Corner Seams
- Cant 3" X 3" X 45°
- 1.5" X 3 LB Density Rigid Insulation

OPTIONAL FEATURES

- Aluminum or Stainless Steel Construction
- 10-16 GA. Material Construction
- Custom Heights (H)
- Pitched Roof Styles
- Burglar Bars
- Damper Shelf
- Custom Pipe Portal Caps
- Solid or Perforated Interior Wall

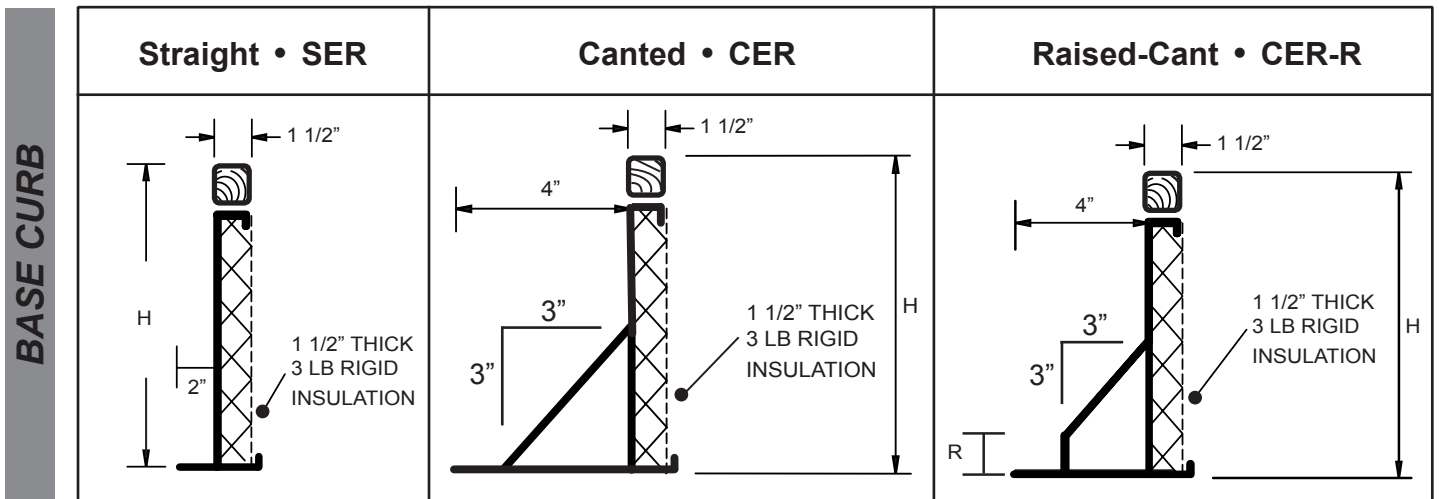

QTY	TYPE	O.D. L x W	I.D. L x W	HEIGHT 'H'	S.I.D. SHELF	RAISE 'R'	GA.	MAT.	NOTE

Please be advised that the purpose of this submittal is to exhibit the overall dimensions of this product. Pictures nor drawings do not give entire detail of product and are not portrayed to scale. Atlantic Fabrication & Coatings reserves the right to alter this submittal without notification.



Atlantic Fabrications & Coatings • 72 Putnam Street • Paterson, NJ 07524 • 201-340-4125

WWW.ATLANTICFABRICATION.COM

RC.4.17-S